

Features

- n Wide 5V to 32V Input Voltage Range
- n Output Adjustable from 0.8V to 30V
- n Maximum Duty Cycle 100%
- n Minimum Drop Out 0.6V
- n Fixed 300KHz Switching Frequency
- n 4A Constant Output Current Capability
- n Internal Optimize Power MOSFET
- n High efficiency
- n Excellent line and load regulation
- n TTL shutdown capability
- n EN pin with hysteresis function
- n Built in thermal shutdown function
- n Built in current limit function
- n Built in output short protection function
- n Available in TO-252 package

Applications

- n LCD Monitor and LCD TV
- n Digital Photo Frame
- n Set-up Box
- n ADSL Modem
- n Telecom / Networking Equipment

General Description

The XL4003 is a 300KHz fixed frequency PWM buck (step-down) DC/DC converter, capable of driving a 4A load with high efficiency, low ripple and excellent line and load regulation. Requiring a minimum number of external components, the regulator is simple to use and include internal frequency compensation and a fixed-frequency oscillator.

The PWM control circuit is able to adjust the duty ratio linearly from 0 to 100%. An enable function, an over current protection function is built inside. When short protection function happens, the operation frequency will be reduced from 300KHz to 60KHz. An internal compensation block is built in to minimize external component count.



Figure1. Package Type of XL4003

Pin Configurations

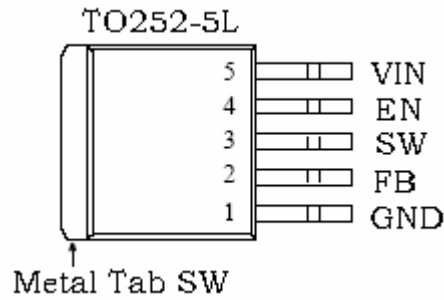

Figure2. Pin Configuration of XL4003 (Top View)

Table 1 Pin Description

Pin Number	Pin Name	Description
1	GND	Ground Pin. Care must be taken in layout. This pin should be placed outside of the Schottky Diode to output capacitor ground path to prevent switching current spikes from inducing voltage noise into XL4003.
2	FB	Feedback Pin (FB). Through an external resistor divider network, FB senses the output voltage and regulates it. The feedback threshold voltage is 0.8V.
3	SW	Power Switch Output Pin (SW). SW is the switch node that supplies power to the output.
4	EN	Enable Pin. Drive EN pin high to turn on the device, drive it low to turn it off.
5	VIN	Supply Voltage Input Pin. XL4003 operates from a 5V to 32V DC voltage. Bypass Vin to GND with a suitably large capacitor to eliminate noise on the input.

Function Block

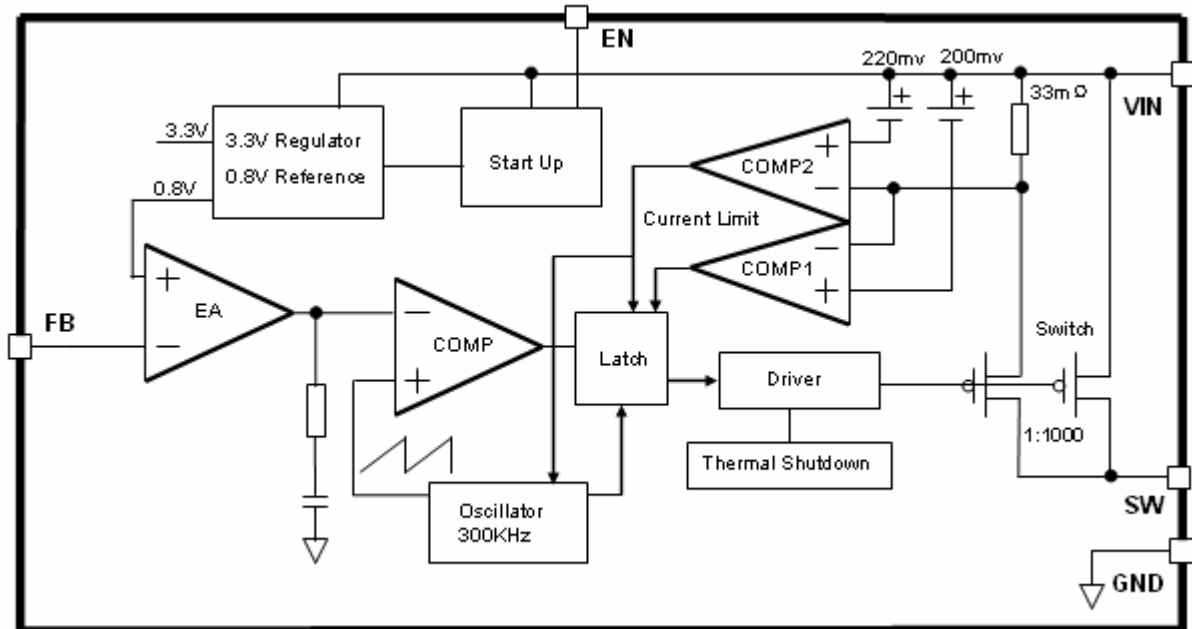

Figure3. Function Block Diagram of XL4003

Typical Application Circuit

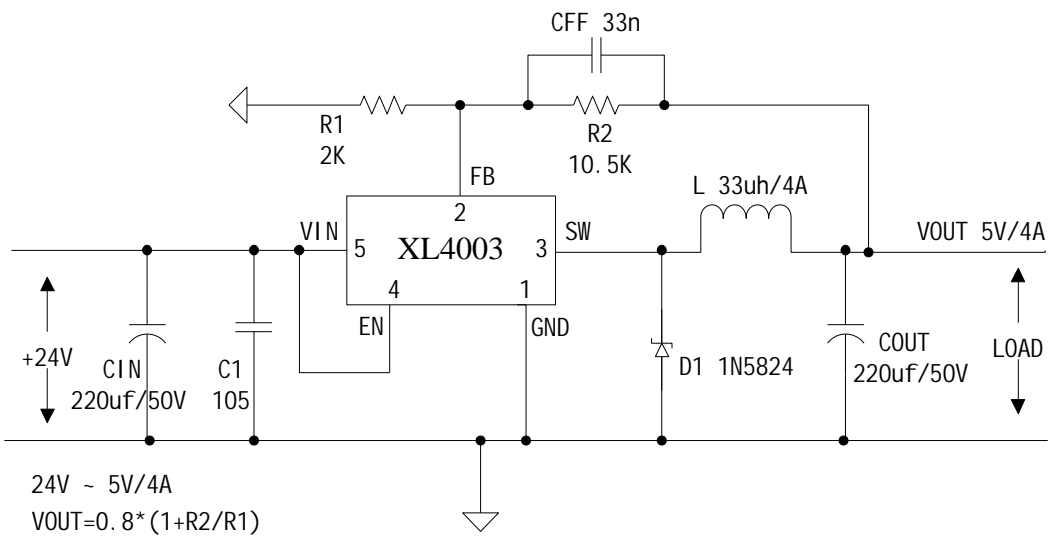

Figure4. XL4003 Typical Application Circuit 24V~5V/4A

4A 300KHz 32V Buck DC to DC Converter

XL4003

Ordering Information

Package	Temperature Range	Part Number	Marking ID	Packing Type
		Lead Free	Lead Free	
		XL4003E1	XL4003E1	Tube
		XL4003TRE1	XL4003E1	Tape & Reel

XLSEMI Pb-free products, as designated with “E1” suffix in the par number, are RoHS compliant.

Absolute Maximum Ratings (Note1)

Parameter	Symbol	Value	Unit
Input Voltage	V _{in}	-0.3 to 35	V
Feedback Pin Voltage	V _{FB}	-0.3 to V _{in}	V
EN Pin Voltage	V _{EN}	-0.3 to V _{in}	V
Output Switch Pin Voltage	V _{Output}	-0.3 to V _{in}	V
Power Dissipation	P _D	Internally limited	mW
Thermal Resistance (TO252) (Junction to Ambient, No Heatsink, Free Air)	R _{JA}	60	°C/W
Operating Junction Temperature	T _J	-40 to 125	°C
Storage Temperature	T _{STG}	-65 to 150	°C
Lead Temperature (Soldering, 10 sec)	T _{LEAD}	260	°C
ESD (HBM)		2000	V

Note1: Stresses greater than those listed under Maximum Ratings may cause permanent damage to the device. This is a stress rating only and functional operation of the device at these or any other conditions above those indicated in the operation is not implied. Exposure to absolute maximum rating conditions for extended periods may affect reliability.

4A 300KHz 32V Buck DC to DC Converter

XL4003

XL4003 Electrical Characteristics

T_a = 25°C; unless otherwise specified.

Symbol	Parameter	Test Condition	Min.	Typ.	Max.	Unit
<i>System parameters test circuit figure4</i>						
VFB	Feedback Voltage	V _{in} = 7V to 32V, V _{out} =5V I _{load} =0.3A to 4A	0.776	0.8	0.824	V
Efficiency	η	V _{in} =12V , V _{out} =5V I _{out} =4A	-	90	-	%

Electrical Characteristics (DC Parameters)

V_{in} = 12V, GND=0V, V_{in} & GND parallel connect a 220uf/50V capacitor; I_{out}=500mA, T_a = 25°C; the others floating unless otherwise specified.

Parameters	Symbol	Test Condition	Min.	Typ.	Max.	Unit
Input operation voltage	V _{in}		5		32	V
Shutdown Supply Current	I _{STBY}	V _{EN} =0V		60	200	uA
Quiescent Supply Current	I _q	V _{EN} =2V, V _{FB} =V _{in}		3	5	mA
Oscillator Frequency	F _{osc}		240	300	360	Khz
Switch Current Limit	I _L	V _{FB} =0		6		A
EN Pin Threshold	V _{EN}	High (Regulator ON) Low (Regulator OFF)		1.4 0.8		V
EN Pin Input Leakage Current	I _H	V _{EN} =2V (ON)		1	15	uA
	I _L	V _{EN} =0V (OFF)		1	15	uA
Max. Duty Cycle	D _{MAX}	V _{FB} =0V		100		%

Test Circuit and Layout guidelines

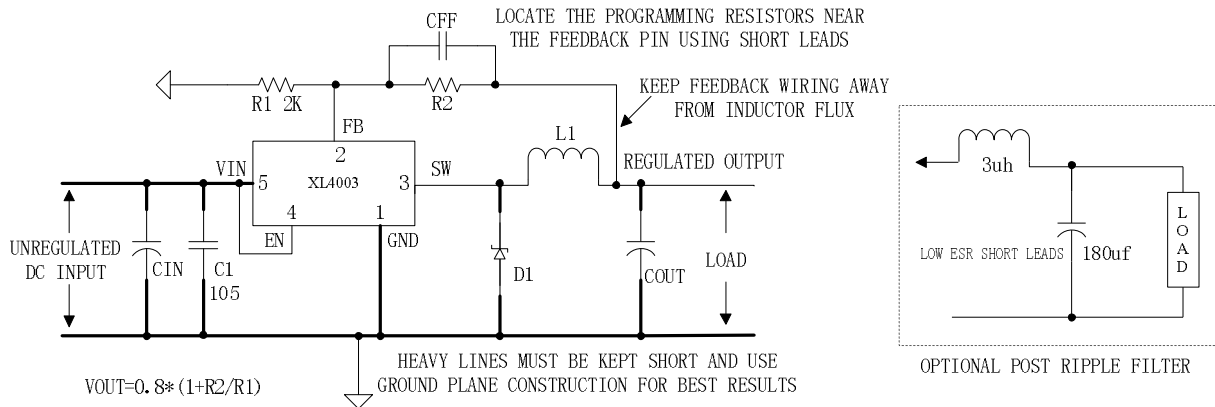

Figure5. Standard Test Circuits and Layout Guides

Select R1 to be approximately 2K, use a 1% resistor for best stability.

C1 and CFF are optional; in order to increase stability and reduce the input power line noise, CIN and C1 must be placed near to VIN and GND;

For output voltages greater than approximately 10V, an additional capacitor CFF is required. The compensation capacitor is typically between 100 pf and 33 nf, and is wired in parallel with the output voltage setting resistor, R2. It provides additional stability for high output voltage, low input-output voltages, and/or very low ESR output capacitors, such as solid tantalum capacitors. $CFF = 1 / (31 * 1000 * R2)$; This capacitor type can be ceramic, plastic, silver mica, etc. (Because of the unstable characteristics of ceramic capacitors made with Z5U material, they are not recommended.)

Schottky Diode Selection Table

Current	Surface Mount	Through Hole	VR (The same as system maximum input voltage)				
			20V	30V	40V	50V	60V
1A		√	1N5817	1N5818	1N5819		
3A		√	1N5820	1N5821	1N5822		
		√	MBR320	MBR330	MBR340	MBR350	MBR360
	√		SK32	SK33	SK34	SK35	SK36
	√			30WQ03	30WQ04	30WQ05	
		√		31DQ03	31DQ04	31DQ05	
		√	SR302	SR303	SR304	SR305	SR306
5A		√	1N5823	1N5824	1N5825		
		√	SR502	SR503	SR504	SR505	SR506
		√	SB520	SB530	SB540	SB550	SB560
	√			50WQ03	50WQ04	50WQ05	

4A 300KHz 32V Buck DC to DC Converter	XL4003
---------------------------------------	--------

Typical System Application for 24V ~ 12V/3A Version

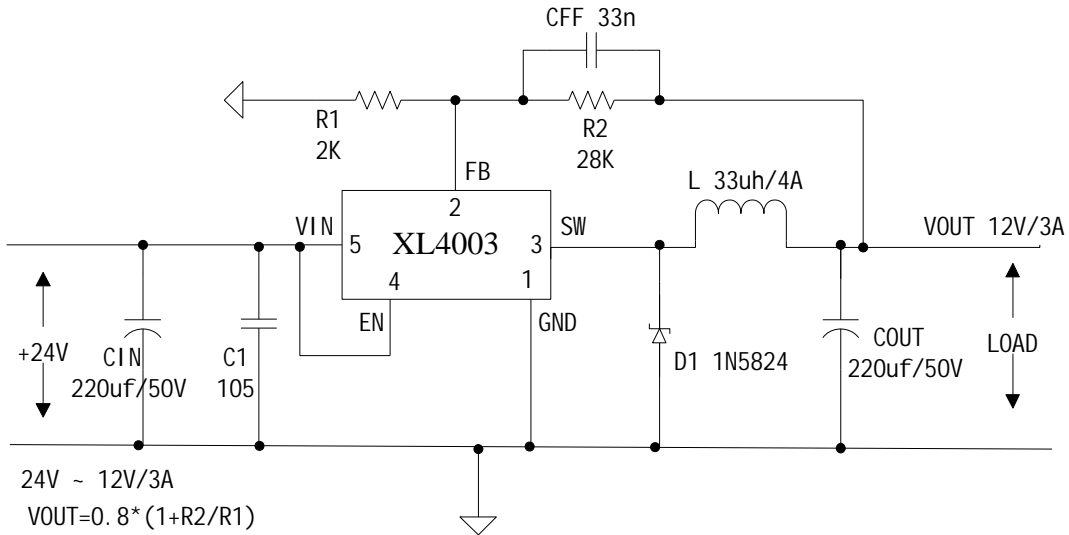

Figure6. XL4003 System Parameters Test Circuit (24V ~ 12V/3A)

Typical System Application for 24V ~ 5V/4A

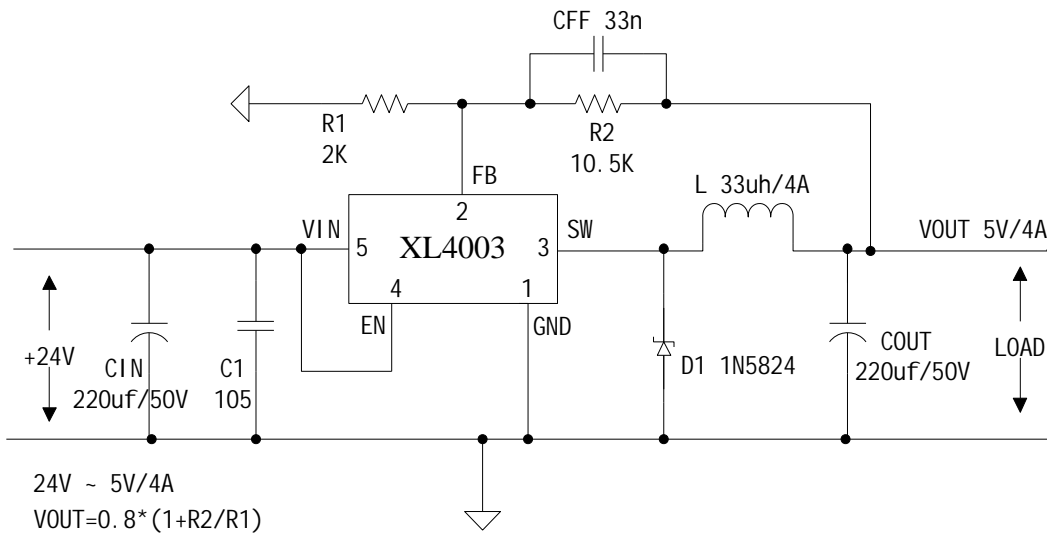
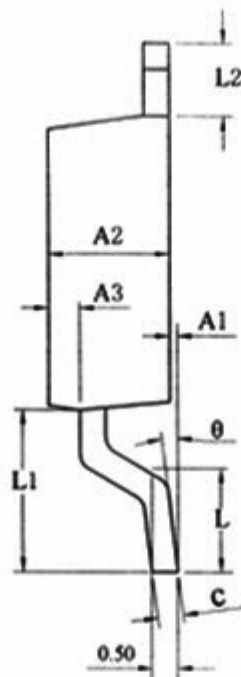
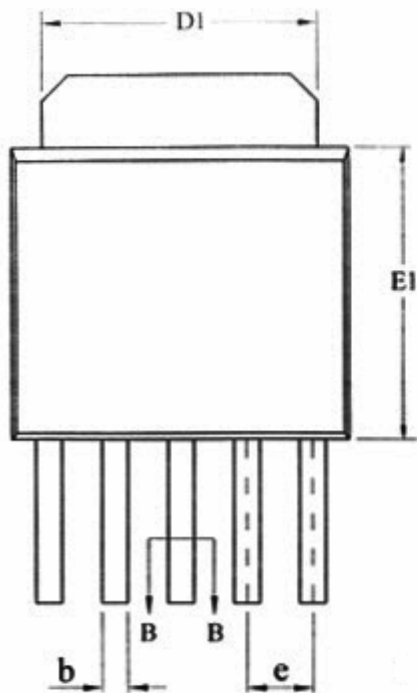

Figure7. XL4003 System Parameters Test Circuit (24V ~ 5V/4A)

Package Information

TO252-5L



SYMBOL	MILLIMETER		
	MIN	NOM	MAX
A1	0.05	0.15	0.25
A2	2.10	2.30	2.50
A3	0.50	0.60	0.70
b	0.46	—	0.60
b1	0.45	0.50	0.55
c	0.49	—	0.56
c1	0.48	0.50	0.52
D	6.30	6.50	6.70
D1	5.30REF		
E1	5.30	5.50	5.70
e	1.27BSC		
L	1.40	1.50	1.60
L1	3.00	3.10	3.30
L2	1.40BSC		
θ	0	—	8°

